

## S.5& S.6 PHYSICS II GUIDE QUESTIONS

1. (a) (i) Define the term *power* of a lens.
- (ii) A finite object placed in front of a convex lens of focal length  $f$  metres, produces a real image of magnification  $m_1$ . The lens is then displaced from the object by a distance,  $d$  and the image of linear magnification  $m_2$  is obtained.

Show that the power  $P$ , of the lens is given by; 
$$P = \frac{m_1 - m_2}{d m_1 m_2}$$

- (b) (i) Distinguish between the *principal focus* and *centre of curvature* of a convex mirror.
- (ii) A car at a distance of 60 m away from a vertical convex mirror of focal length 15 cm, is driven towards the mirror at a speed of  $30 \text{ ms}^{-1}$ . Find the speed of the car's image in the mirror.
- (c) (i) What is chromatic aberration?
- (ii) Explain how chromatic aberration is minimized in a photographic Camera.
- (d) Describe an experiment to determine the refractive index of water using a plane mirror and an equi-convex lens of known radii of curvature

2. (a) (i) Define the term *focal length* of a lens.
- (ii) Using a concave lens, derive the formula relating the object distance,  $u$ , the image distance,  $v$  and the focal length,  $f$ , of the lens.
- (b) (i) What is meant by the term *visual angle*?
- (ii) Explain why the front wagons of a train appear to an observer standing in front of the train, to be larger than the rear wagons.

- (c) (i) Define the term *exit pupil* of an optical instrument and explain its Significance to an observer using the instrument.
- (ii) State *two advantages* of a Galilean telescope over astronomical telescope.
- (d) An astronomical telescope having an objective of diameter 15.0 cm and focal length 100 cm and an eyepiece of focal length 5.0 cm is used in normal adjustment. Find the:-
  - (i) position of the eye-ring.
  - (ii) diameter of the eye-ring.

3. a) Define the focal length of a concave mirror.
- (b) Suppose a concave mirror forms an image of a real object placed at distance  $U$  from it at a distance  $V$ . draw a ray diagrams to represent the path taken by light rays when the image formed is.
- (i) Real
  - (ii) virtual
- (c) A concave mirror with a radius of curvature of 40cm forms an image of a real object, which has been placed 25cm from the mirror.
- (i) What is the focal length of the mirror
  - (ii) Calculate the distance of the image from the mirror and state whether it is real or virtual
- (d) Describe how a sextant is used to measure the angle of elevation of a star.
- (e) Explain with the aid of a diagram why a thick plane mirror forms multiple images.

4. a) (i) State the conditions for minimum deviation,  $D$  to occur in a glass prism of refracting angle,  $A$  and a refractive index,  $n$ ,
- (ii) Show that the refractive index of the material of the prism in (i) above is given by
- $$n = \frac{\sin \frac{A+D}{2}}{\sin \frac{A}{2}}$$
- (b) The refractive index of diamond with respect to air is 2.42. Calculate the critical angle for diamond air boundary
- (c) A compound microscope consists of two thin converging lenses. The focal length of the objective lens is 1.0cm and that of eye piece lens is 2.0cm. If an object is placed 1.1cm from objective lens, the instrument produced an image at infinity.
- (i) Draw a ray diagram showing the instrument in the arrangement
- (ii) Calculate the separation of the lenses
- (iii) Derive the expression of magnifying power of the instrument
- (iv) Calculate its magnifying power
5. (a) Define
- (i) focal plane
- (ii) aperture of a lens
- (b) Describe how the focal length of a convex lens may be determined by a method involving graphical analysis
- (c) A concave lens of focal length 18cm is arranged coaxially with a convex lens of focal length 24cm, placed 4cm apart. An object is placed 30cm in front of the concave lens on the side remote from the convex lens.
- (i) Find the position of the final image

- (ii) Using a point object draw a ray diagram to show the image formation
- (d) (i) Explain why a parabolic mirror is used in search lights instead of a concave mirror
- (ii) Explain two advantages of reflecting telescopes over refracting ones
6. (a) Describe how the refractive index of a material of a prism may be determined using a spectrometer.
- (b) Define angular magnification of an optical instrument and eye ring
- (c) (i) Draw a ray diagram to show a Galilean telescope with the final image at the near point.
- (ii) Derive the angular magnification of the telescope in this setting
- (d) An astronomical telescope has an objective of focal length 120cm and an eye piece of focal length 8cm. If the telescope forms the final image 300cm from the eye piece, find the
- (i) Separation of the lenses
- (ii) Angular magnification
7. (a) What is refraction of light?
- (b)

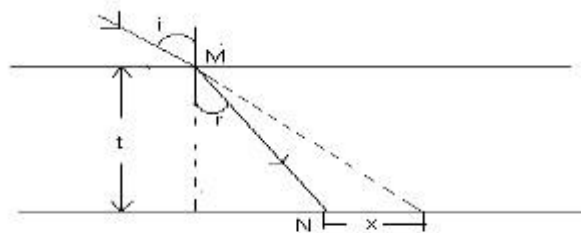

Figure 1

Figure 1 above shows a ray of light from air incident on a parallel sided glass block of thickness  $t$  at  $M$ , at an angle,  $i$ , and is

refracted through angle,  $r$ , to pass through N, (i)  
 List three factors that determine the lateral displacement,  $x$ .

(ii) Show that  $\frac{x}{t} = \tan i - \tan r$ .

(c)

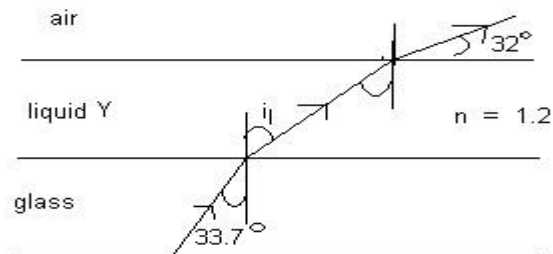

Figure 2

Figure 2, shows a ray of monochromatic light from glass, passing through liquid Y, and emerging into air. If the refractive index of Y is 1.2, and the ray emerges as shown, find

- (i) The refractive index of the glass.
  - (ii) The deviation due to refraction at the glass-liquid interface.
- (d) Describe how the refractive index of a material of glass prism of known refracting angle can be obtained using a spectrometer.
- (e) A piece of stone at the bottom of a water- tank viewed from directly above the water appears displaced by 0.2m. If the refractive index of water is 1.33, find the depth of water in the tank.

8. (a) (i) Draw a ray diagram to show how a convex mirror forms an image of a real object.
- (ii) Describe how you could determine the focal length of a convex mirror using a convex lens.
- (b) An object is placed at a distance,  $d$ , on one side of the principle focus,  $F$ , of a convex lens of focal length  $f$ . The image is formed at some point  $C$ . Show that when the object is displaced to a point distance,  $d$ , on the opposite side of,  $F$ , the image gets displaced by distance  $\frac{2f^2}{d}$ .

- (c) The objective and eye piece of an astronomical telescope have focal lengths of 95cm and 5cm respectively. Find the:
- Separation of the two lenses when the final image is formed at 150cm from the eye Piece.
  - Position of the eye ring.
- (d) (i) What is the significance of the eye ring of an astronomical telescope?
- (ii) State two advantages of a reflecting telescope over a refracting telescope.
9. (a) (i) State the laws of reflection of light.
- (ii) Considering a convex mirror, show that;  $\frac{1}{u} + \frac{1}{v} = \frac{1}{f}$  where  $u$ ,  $v$  and  $f$  are object distance, image distance and focal length of the mirror.
- (b) A converging lens is fixed inside a tube and cannot be accessed. Describe an experiment to measure its focal length.
- (c) (i) Define conjugate points in relation to a lens.
- (ii) A converging lens is placed 10.5m in front of a screen which is 2.5cm<sup>2</sup>. If the slide used in order that the pictures fill the whole screen has an area of 8cm<sup>2</sup>; Calculate the focal length of the lens.
10. (a) (i) Name at least four examples when total internal reflection occurs.
- (II) Explain in detail the occurrence of one of the examples in (i) above.
- (b) (i) Describe an experiment to measure refractive index of a liquid using an air cell.

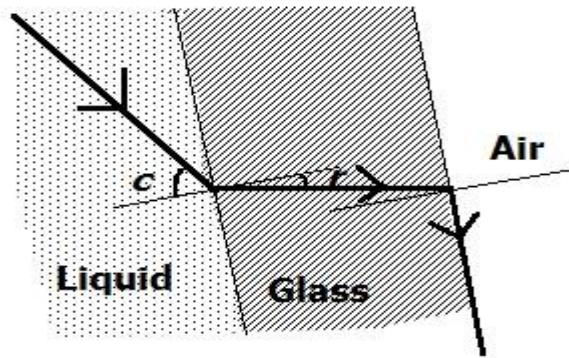

Fig.1

In figure 1, a parallel sided glass slide is in contact with a liquid on one side and air on the other side. A ray of light incident on the glass slide from the liquid emerges in air along the glass-air interface. Derive an expression for the absolute refractive index,  $n_i$ , of the liquid in terms of the absolute refractive index,  $n$ , of glass and the angle of incidence,  $i$ .

- (c) (i) Draw a ray diagram to show the formation of an image of a distant object in a terrestrial telescope in normal adjustment.
- (ii) State two disadvantage of the terrestrial telescope.
11. (a) State the laws of reflection of light
- (b) (i) Draw a ray diagram to show the formation of the image of a finite object by a diverging mirror.
- (ii) Use the diagram drawn in b (i) above to derive the expression of the mirror formula.
- (c) Describe an experiment to determine the focal length of a diverging mirror by a converging lens.
- (d) An object is placed 15.0 cm in front of a concave mirror of focal length 10.0 cm, by what distance should the object be shift in order to obtain; (i) a real image a half the size of the object.
- (ii) a virtual image twice the size of the object.
12. (a) Distinguish between Principal foci and Conjugate foci of a lens.

- (b) Explain why two poles of different height appears to be the same height to an observer.
- (c) (i) Describe an experiment to determine the focal length of a lens by displacement of the lens method  
(ii) State two advantages of the method in c (i) above.
- (d) (i) With the aid of diagram derive the expression for angular magnification of the Galilean Telescope.  
(ii) A Galilean telescope is used to focus a distant object with the eye piece placed 50cm from the objective lens. The focal lengths of the objective and the eye piece are 100cm and 10 cm respectively. Find the distance from the objective lens where the final image will be formed.  
(iii) State the Problem of the arrangement of the lenses in this telescope.

13. (a) (i) State the laws of refraction  
(ii) What is meant by the term critical angle?
- (b) Describe giving the relevant equations, how the refractive index of the liquid can be determined by using a convex lens of known radius of curvature
- (c) A child is 1.4m tall and her eyes are 10cm below the top of her head. She wishes to see the whole length of her body in vertical plane mirror whilst herself is standing vertically.
- (i).What is the minimum length of the mirror that can make this possible?
- (ii). How far above the ground is the top of the mirror?
- (d) (i). Define magnifying power of an optical telescope

(ii). Describe the structure and mode of action of an astronomical telescope. Derive the expression for its magnifying power when used so that the final image is at infinity.

14. (a) (i) Define reflection
- (ii). When a plane mirror is turned through an angle  $\alpha$ , the reflected ray turns through an angle  $\beta$ . Derive the relationship between  $\alpha$  and  $\beta$
- (b) Describe an experiment to determine the focal length of a diverging mirror using a plane mirror.
- (c) (i). Derive an expression for the combined focal length,  $F$ , of a thin convex lens of focal length  $f_1$ , in contact with a thin concave lens of focal length  $f_2$ .
- (ii). A thin equi-convex lens made of glass of refractive index 1.5 is placed on a horizontal plane mirror. A thin pin fixed 15cm above the lens is found to coincide in position with its own image. When the space between the plane mirror and the equiconvex lens is now filled with a liquid; the point of coincidence of the pin and its image is found to be 27cm. Find the refractive index of the liquid.
- (d) Explain why two different objects  $O_1$  and  $O_2$  of different heights  $h_1$  and  $h_2$  would always appear to be of the same height

### SECTION B

1. (a) (i) Distinguish between *free and damped oscillations*.  
(ii) Give one example of each oscillation in (i).

- (b) (i) Define the term *resonance*.
- (ii) Describe the graphical method of measurement of the velocity of sound in air using a resonance tube.
- (c) (i) State the laws of vibration of a stringed instrument.
- (ii) Explain how standing waves are formed in a stringed instrument.
- (d) A sonometer wire of diameter 1.5 mm and length 0.500 m, made of a material of density  $7800 \text{ kg m}^{-3}$  is plucked at its mid-point to set it into vibration at its fundamental frequency and resonate with a vibrating tuning fork of frequency 516 Hz. Find the tension in the wire.

2. (a) (i) What is plane polarized light?
- (ii) Describe one application of plane polarized light.

- (b) (i) Define the terms *Doppler effect*, and *beats*.
- (ii) A pedestrian moving along a straight road towards a vertical wall is followed by a police car moving at  $108 \text{ km h}^{-1}$  sounding its siren at frequency 500Hz. The pedestrian hears beats at a rate of  $6.0 \text{ s}^{-1}$ . Find the speed of the pedestrian.

- (c) (i) Define the term interference of waves.
- (ii) State the conditions necessary for observation of interference patterns in young's double slit experiment.

- (d) (i) Explain the term lens blooming.
- (i) Give one use of bloomed lenses.

3. a) Explain the terms wavelength and wave front, as applied to the motion at wave.

- (b) (i) Define the term resonance

(ii) Describe how velocity of sound in air is determined using a resonance tube

- (c) Using suitable diagrams derive the expressions for the first three overtones of a vibrating wire fixed at both ends in terms of the fundamental frequency  $f_0$  of the fundamental note.
- (d) A steel wire hangs vertically from a fixed point, supporting a weight of 160N at its lower end. The length of the wire from the fixed point to the weight is 3.0m. Given that the density of the steel is  $7800\text{kgm}^{-3}$  and the diameter of the steel wire 1.0mm, calculate the fundamental frequency emitted by the wire when it is plucked.
4. a) State Huygens's principle
- (b) Use Huygens's principle to derive the relation between critical angle and refractive indices of two media in contact.
- (c) Explain the formation of beats and derive the expression for the beat frequency.
- (d) A tuning fork of frequency 256HZ is used to tune the sonometer wire of length 0.85m. The vibrating length of the wire is then shortened to 0.80m
- (i) What would be the new length of the string when plucked?
- (ii) What would be the beat frequency heard when the tuning fork and the shortened wire are sounded together.
- (e) Explain why the sky appears blue on a clear day.

5. (a) State the principle of superposition of waves
- (b)

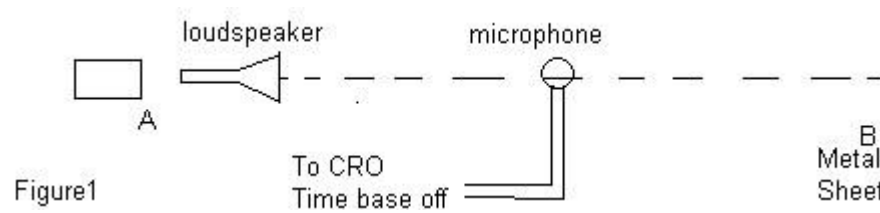

Figure1 shows a loudspeaker which produces a note of constant frequency. When a microphone connected to a C.R.O is moved from A to B, the length of the vertical trace on the C.R.O continually changes between maximum and minimum at equal distance

- (i) Explain the above observation.
- (ii) Describe how you would use the above experiment to determine the velocity of sound in air
- (c) What is meant by: (i) fundamental frequency and  
(ii) beats
- (d) Two open organ pipes of length 50cm and 51cm give beats of frequency 6.0Hz when sounding their fundamental notes together
- (i) Neglecting end corrections, find the velocity of sound in air at that time.
- (ii) If the above experiment was carried out in a room at  $0^{\circ}\text{C}$ , find the velocity of sound at  $27^{\circ}\text{C}$ .
- (e) (i) Distinguish between mechanical and electromagnetic waves  
(ii) Explain the factors that determine the velocity of sound in air
6. (a) (i) What is meant by interference and diffraction of light waves

(ii) State the condition necessary for formation of observable diffraction.

(b) With a given diffraction grating used at normal incidence, a yellow line of wavelength

$\lambda = 6.0 \times 10^{-7} \text{ m}$  in one spectrum coincides with a blue line of  $4.8 \times 10^{-7} \text{ m}$  in the next order spectrum. If the angle of diffraction for these two lines is  $30^\circ$ , calculate the spacing between the grating lines.

(c) (i) Describe how interference is formed in an air wedge.

(ii) Explain the change in fringe pattern which occurs if the air in the wedge is replaced by transparent oil.

(iii) Give two applications of interference of light.

(d) The refractive index for light passing from air to medium X is 1.4. The speed of light in air is  $3.0 \times 10^8 \text{ ms}^{-1}$ . Calculate the:

(i) Speed of light in medium X

(ii) Wavelength of light of frequency  $5.7 \times 10^{14} \text{ Hz}$  in medium X.

7. (a) (i) What is meant by the terms free and damped oscillations?

(ii) Describe how a forced oscillation can build up into large energy oscillation.

(b) (i) Describe how you can determine the velocity of sound in air using a glass tube and a single tuning fork.

(ii) From the experimental values in b (i) above deduce the expression for the end correction of the glass tube.

(c) (i) What is meant by beats?

(ii) Calculate the frequency of beats heard by a stationary observer when a source of sound of frequency  $69 \text{ Hz}$  is receding with a speed of  $70 \text{ ms}^{-1}$  towards a vertical wall.

(iii) State two uses of beats.

8. (a) (i) State the conditions necessary for formation of observable interference due to two waves.
- (ii) Explain why an oil film on a water surface appears to be coloured.
- (b) In young's double slit experiment, the apparatus are set up to produce interference fringes on the screen. Explain how the following adjustments improve the accuracy of measurement of fringe widths.
- (i) Moving the source slit closer to the secondary slits.
- (ii) Moving the screen further away from the secondary slits.
- (iii) Replacing double coloured light with monochromatic light.
- (c) Two glass slides in contact at one end are separated by a sheet of paper 15cm from the line of contact to form an air wedge. When the air wedge is illuminated normally by light of wave length  $5.8 \times 10^{-7}m$ , interference fringes of separation 1.6mm are found in reflection. Find the thickness of the paper.
- (d) State two uses of interference.

9. (a) (i) Define wave front, and phase difference in relation to waves.

(ii) Draw a sketch diagram showing reflection of a circular wave by a plane reflector.

(b) Distinguish between progressive and stationary waves.

(c) The displacement in metres of a plane wave is given by the equation

$$y = 0.2 \sin \left[ \pi \left( 200t - \frac{20}{17}x \right) \right]$$

Find;-

i. Wave length.

ii. Speed of the wave.

- (d) (i) Describe an experiment to determine the velocity of sound in air using the resonance method.
- (ii) A tube 1m long closed at one end has its lowest resonance frequency at 86.2Hz. With a tube of identical dimensions but open at both ends, the first resonance occurs at 171Hz. Calculate the speed of sound and end correction.

10. (a) Distinguish between constructive and destructive interference.

- (b) (i) Explain how interference fringes are formed in an air-wedge film between two glass slides when monochromatic light is used.
- (ii) Describe the appearance of the fringes when white light is used.

(c) Two glass slides in contact at one end are separated by a sheet of paper 15cm from the line of contact to form an air wedge. When the air-wedge is illuminated normally by light of wavelength  $6.0 \times 10^{-7}\text{m}$ , interference fringes of separation 1.8mm are found in reflection. Find the thickness of the paper.

- (d) (i) Describe with the aid of a labeled diagram, one method of producing plane polarized light.
- (ii) State two uses of polarized light.

11. (a) State two differences of *electromagnetic waves* and *Mechanical waves* and give one example of each.

(b) (i) Define the term *Doppler effect*.

(ii) An observer is moving in a straight line between two identical stationary sources of sound, from one source towards the other, each emitting sound of frequency 500Hz, hears beats at a rate of  $4.0 \text{ s}^{-1}$ . If the velocity of sound in air at the time of observation is  $340 \text{ ms}^{-1}$ . Derive the expression for the velocity of the observer and hence determine the velocity of the observer.

(c) Describe an experiment to determine the speed of sound in air by the dust tube method.

- (d) (i) Define the term *resonance* and state two applications of resonance .
- (ii) In the dust tube experiment, the vibrating air due to a nearby loud speaker causes 7 consecutive heaps of powder to occupy a total distance of 0.60 m when the air in the tube is set into resonance at a frequency  $f$ . Determine the value of the frequency  $f$ .
12. (a) (i) State Huygens' principle.
- (ii) Use Huygens' principle to show that when light waves travel from a medium of lower optical density of absolute refractive index  $n_1$  to that of higher optical density of refractive index  $n_2$ , the ratio of the velocities of light in the media is inversely proportional to the ratio of their refractive indices.
- (b) (i) What is polarized light?
- (ii) Derive an expression for Brewster's law for ordinary light incident from optical medium A of refractive index  $n_A$  at a polarizing angle  $\alpha$ , to medium B of refractive index  $n_B$ .
- (c) (i) Define the term *interference* of waves.
- (ii) Explain how interference of waves is achieved by division of wave front.
- (d) (i) Describe how the fringe separation is obtained in Young's double slit experiment.
- (ii) Young's fringes are formed using slits separated by 0.60mm and projected onto a screen at a distance of 1.4m. Twelve fringe separations occupy 16 mm. Determine the wavelength of the light used.
13. (a) (i). What is meant by the Doppler effect?

(ii). Explain one application of Doppler effect?

(b) (i). A source which is emitting sound waves of frequency  $f_0$  is travelling at a speed,  $u$ , towards an observer who is travelling with speed,  $v$ , in the same direction. Derive an expression for the frequency  $f$  heard by the observer.

(ii). An engine travelling at a constant speed towards a tunnel emits a short burst of sound of frequency 400Hz which is reflected from the tunnel entrance. The engine driver hears an echo of frequency 500Hz two seconds after the sound is emitted.

Assuming the speed of sound is  $340\text{ms}^{-1}$ ; calculate the speed of the engine

(c) Describe an experiment to determine the speed of sound using a measuring cylinder, paper cone, lycopodium powder and oscillator

(d) Explain why the quality of the note from the closed pipe differs from that given by an open pipe

14. (a) (i). Distinguish between interference and diffraction  
(ii). State one condition for diffraction to occur

(b) Describe an experiment to determine the wavelength of light using diffraction grating and spectrometer.

(c) Derive an experiment for the wavelength,  $\lambda$  in Newton's double slit experiment with slit separation,  $d$ , and the distance between the screen and the slits as  $x$

(d) With careful explanation, deduce the diffraction grating formula  $n\lambda = d \sin\theta$ , where  $n$

is the number of lines.

- (e) The speed  $C$  of a transverse progressive wave travelling along a stretched string of

mass per unit length  $\mu$  is given by  $C = \sqrt{\frac{T}{\mu}}$ , where  $T$  is the tension in the string. Show that the equation is dimensionally correct.

### SECTION C

#### A. MAGNETISM AND ELECTROMAGNETIC INDUCTION

1. (a) (i) Define the term *ampere*.
- (ii) Figure 1 shows two straight parallel wires A and B of equal lengths  $L$ , held on smooth inclined planes at  $45^\circ$  to the horizontal at point O. Wire A, carrying a current of  $9.81\text{A}$  is fixed

while B carrying a current of 5.0A in the opposite direction is free to move.

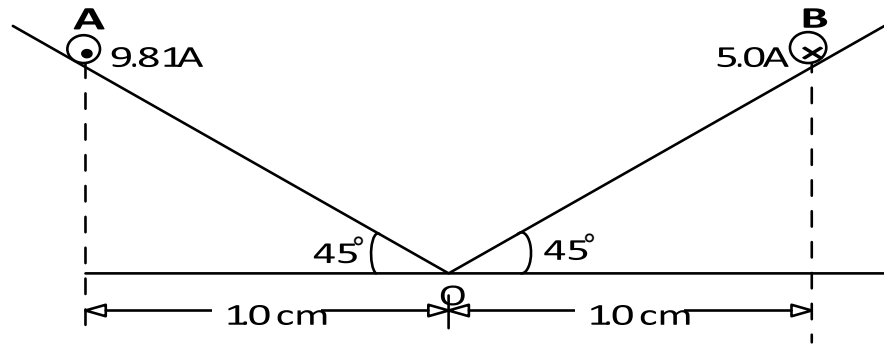

Fig 1

If B is just prevented from sliding down the inclined plane, determine the length  $L$  of each wire, if the mass of wire B is 20 mg.

- (b) (i) State *three factors* that determine the magnitude of the magnetic force experienced by a straight conductor carrying a current in a magnetic field.
- (ii) Explain the effect of one of the factors in (i) above on force experienced by the conductor.
- (c) (i) What is meant by the term *magnetic torque* and state its S.I. unit.
- (ii) A small square coil of side 2cm is freely suspended at the centre of a large plane circular coil of radius 7cm, having 210 turns each carrying a current of 5A, so that the initial angle between the planes of the coils is  $30^\circ$ . When a current of 4A is passed through the small coil, it turns about its axis of suspension through radians. Determine the torsion suspension constant of the supporting wire.
- (d) Give two industrial uses of magnets
2. (a) (i) State the laws of electromagnetic induction.
- (ii) Describe an experiment to verify Lens's law.

- (b) A small circular coil of 10 turns each of radius 5 cm is held with its plane perpendicular to a strong uniform magnetic field of flux density  $B$ . The coil is then flipped through an angle of  $60^\circ$  about its horizontal diameter in a time of 0.25 s and an e.m.f. of 3.14 mV is induced in it. Find the value of  $B$ .
- (c) (i) What are eddy currents?
- (ii) State four uses of eddy currents.
- (d) An electric motor having an armature coil of resistance  $2\Omega$  is connected across a 240V source. When a current of 5A is passed through the coil, the motor rotates at a speed of 300 revolutions per minute. When the motor is loaded, the armature current drops to 3.5A. Find the new speed of the motor when loaded.
3. a) (i) Write down the expression for the force on a charge  $e$  coulombs moving with velocity  $V$  at angle, of flux density  $B$
- (ii) Use the expression in a(i) above to deduce the expression of force on a conductor carrying a current  $I$  in a magnetic field.
- (iii) A solenoid of 2000 turns and length 20cm is lined up so that its axis is parallel to Earth's field lines. The strength of the field is  $140\mu\text{T}$  at position of the solenoid. Calculate the current in the solenoid which will create a magnetic field of the same strength as the Earth's field.
- (b) (i) describe an experiment to investigate the dependence of magnetic flux density at the centre of a circular coil on current through the coil using a search coil. (ii) The search coil has 100 turns and diameter of 35mm. it is connected in series with the resistance box and ballistic galvanometer. The total resistance of the circuit is 5000 ohms. The charge sensitivity of the meter is  $0.02\mu\text{cmm}^{-1}$ . The search coil is placed

between the poles of a horse shoe magnet with the field lines at right angles to the coil. When the search coil is rapidly withdrawn from the field, a first throw of 85mm is measured. Calculate the magnetic field strength between the poles of the horse shoe magnet.

4. a) (i) Distinguish between self-induction and mutual induction.

(ii)

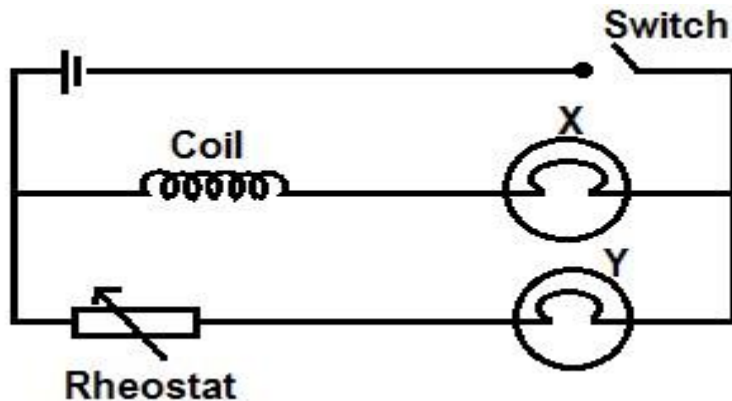

The figure above show a coil connected in services with lamp X. A second lamp Y is in series with a rheostat is connected in parallel with the coil and lamp X. explain what happens when switch is closed.

- (b) Explain how the Hall voltage,  $V_H$ , builds up between the opposite edges of a rectangular conductor placed in a magnetic field, when the current  $I$  flows at right angles to field across the conductor.
- (ii) Derive the expression for the Hall voltage in b(i) above.
- (c) A strip of metal foil of thickness 0.1mm carries a current of 5.0A. When magnetic field strength 0.2T is directed into the foil at right angles to its plane, a p.d across its edges is produced by a hall effect. Measurement of the p.d gives a value of  $6.25\mu\text{V}$  for a current of 5.0A. Calculate the number of charge carrier per unit volume given the charge of each carrier is  $1.6 \times 10^{-19}\text{C}$ .

5. (a)

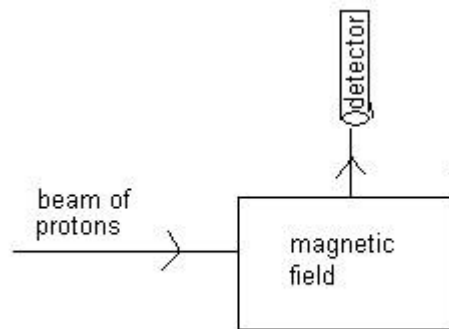

Figure 2

Figure 2 shows an arrangement for deflecting charge into a detector. When protons enter the magnetic field of flux density  $0.5\text{T}$ , with speed of  $4.8 \times 10^6 \text{ms}^{-1}$  they are deflected to enter the detector as above

- (i) State the direction of the magnetic field
  - (ii) Calculate the magnitude of force on each proton.
  - (iii) If instead, a beam of electrons was directed along the same path into the field with the same velocity, state two changes that would need to be made on the magnetic field for the electrons to enter the detector along the same path
- (b)
- (i) With the aid of an appropriate diagram derive the expression for the magnetic torque experienced by a rectangular coil of  $N$  turns and dimensions  $a \times b$  placed in a uniform magnetic field of flux density  $B$ , with its plane inclined to the field of an angle  $\theta$ , and a current  $I$  is flowing through it.
  - (ii) A square coil of side  $3\text{cm}$  has  $150$  turns. The coil is mounted inside a solenoid of  $600$  turns per metre such that its plane makes an angle  $30^\circ$  with the axis of the solenoid. If the coil is connected in series with the solenoid and a current of  $1.2\text{A}$  is passed through the system, find the initial torque on it.

- (c) Explain why a moving coil galvanometer should have a radial magnetic field, fine hair springs and many turns
6. (a) (i) With the aid of a diagram explain how a simple d.c motor works  
(ii) Explain the significance of a back emf in the operation of a d.c motor.
- (b) A motor of armature resistance  $1.2\Omega$  is operated from 240V d.c supply
- (i) When the motor turns freely without a load, the current in the armature is 4.0A and the motor makes 400 revolutions per minute. Calculate the mechanical power converted.
- (ii) When a load is placed on the motor, the armature current increases to 60.0A.  
Find the new speed of rotation of the motor.
- (c) An air-cored inductor is connected in series with a switch and a d.c source. The switch is closed and left for some time. Explain why sparks is observed across the switch contacts when the switch is re-opened.
- (d) (i) What are eddy currents?  
(ii) Describe one application of eddy currents.
7. (a) Define the terms magnetic flux and magnetic flux density.
- (b) A straight wire of length 30cm and resistance  $0.36\Omega$  lies at right angles to a magnetic field of flux density 0.45T. The wire moves when a p.d of 2.0V is applied across its ends. Calculate the:
- (i) Initial force on the wire.  
(ii) Force on the wire when it moves at a speed of  $12\text{ms}^{-1}$ .  
(iii) Maximum speed attained by the wire.

(c) (i) Using an illustrative diagram, explain why a current carrying conductor in a

magnetic field experiences a force.

(ii) Draw a magnetic field pattern for two current carrying wires experiencing attractive force.

(d) Describe with the aid of a diagram an absolute method of determining resistance.

8. (a) (i) What is meant by mutual induction?

(ii) Name one device whose action is based on mutual induction.

(b) Describe an experiment to demonstrate mutual induction.

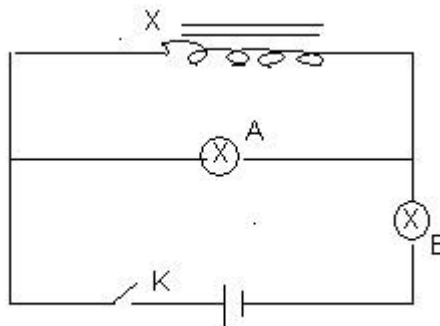

Figure 3

Two identical bulbs A and B are connected to an inductor, X, of large inductance as shown in Figure 3 above. Explain what is observed when,

(i) Switch K is first closed.

(ii) Switch K is opened.

(d) A flat circular coil of 600 turns, each of radius 8cm is rotated at a frequency of 180

revolutions per minute about an axis along its diameter, at right angles to a uniform magnetic field of flux density 0.22T.

Calculate the;

- (i) e.m.f induced in the plane when the plane of the coil makes an angle of  $30^\circ$  with the magnetic field.
- (ii) r.m.s current which flows in the circuit if a resistor of resistance  $3\Omega$  is connected across the coil.
- (e) With the aid of a circuit diagram describe how a full wave rectifier works.

9. (a) Define magnetic flux density.

- (b)
  - (i) A circular coil of a moving coil loud speaker is in a magnetic field of magnitude  $0.40\text{T}$ . The coil has 50 turns of average length  $50\text{mm}$  each. Calculate the instantaneous force the coil experiences when a current of  $0.15\text{A}$  is passed through it.
  - (ii) Describe an experiment to show the variation of magnetic flux density at the centre of a narrow coil with current in the coil.

(c) Write the expression for magnetic flux density for the following current-carrying conductors.

(i) at a point close to a straight conductor.

(ii) at the centre of a narrow coil.

(iii) on the axis of a long solenoid.

(d) Two long straight conductors placed  $0.5\text{cm}$  apart carry currents of  $10.0\text{A}$  and  $2.0\text{A}$  respectively in opposite directions. Calculate the forces the conductors exert on

0.1m length of each other, assuming they are in air.

10. (a) State the laws of electromagnetic induction.

(b) (i) A circular metal disc of radius,  $R$ , rotates in an anticlockwise direction at an

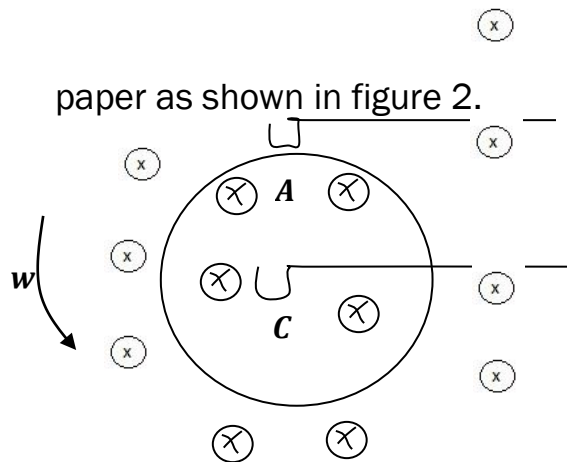

Fig.2

angular velocity,  $w$  in a uniform magnetic field of flux density,  $B$  directed into the page. A and C are contact points. Derive an expression for the *emf* induced between A and

C.

(ii) A flat circular coil with 2000 turns, each of radius 50cm, is rotated at a uniform rate of 600 revolution per minute about its diameter at right angles to a uniform magnetic flux density  $5 \times 10^{-4} T$ . Calculate the amplitude of the induced *emf*.

(c) (i) With the aid of a labeled diagram, describe the structure and action of a simple *d.c* motor.

(ii) Explain the term back *e.m.f* in a motor and derive its relation to the efficiency of the motor.

(iii) State any two factors which lead to energy losses in the motor.

11. (a) (i) Distinguish between magnetic flux and magnetic flux density of a uniform magnetic field.

(ii) Sketch a magnetic field pattern of a current carrying conductor placed in the earth's magnetic field and use it to explain a neutral point.

(b) Describe the mode of operation of the moving coil galvanometer.

(c) A circular coil of 50 turns each of radius 12.0 cm is placed vertically inside a solenoid of 1000 turns per metre with its plane perpendicular parallel to the axis of the solenoid. If currents of 2A and 3A are passed through the solenoid and the coil respectively, Find the

(i) magnetic flux linkage with the coil.

(ii) initial torque on the coil

(d)

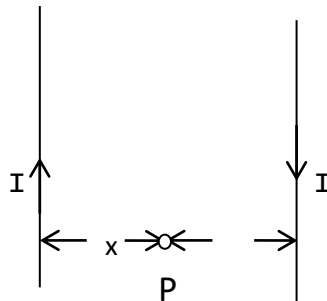

**Fig. 1**

Figure 1 shows two parallel straight wires, a distance  $y$  apart, carrying current of  $I$  in air.

(i) Show that the magnetic flux density  $B$  at point  $P$  is

$$B = \frac{10^{-7} I y}{x(y-x)}$$

(ii) Find the force per metre acting on the wires if  $I = 2A$  and  $y = 4$  cm.

12. (a) (i) Distinguish between back e.m.f and eddy currents

(ii) Describe an experiment to verify Lenz's law.

- (b) (i) A metal disc of radius,  $a$  is placed in a uniform magnetic field of flux density  $B$  of the disc.
- (ii) A circular aluminium disc of radius 30 cm is mounted inside a long solenoid of 2000 turns per metre carrying current of 15A, such that its axis is along the axis of the solenoid. If the disc is rotated about its axis at 40 revolutions per minute, find the *e.m.f* induced.
- (c) With the aid of a diagram describe the mode of action of an a.c generator

13.

- (a) (i). Define a tesla
- (ii). Write down the expression for the force exerted on a straight wire of length  $L$ , carrying current,  $I$ , at right angle to the magnetic flux density  $B$ .
- (b) (i). Two long conductors carrying current are placed parallel to each other in vacuum at a distance,  $d$ , metres apart. Derive an expression for the force per unit length acting on each wire when a current,  $I_1$ , amperes flows in one and  $I_2$ , amperes through the other.
- (ii). How does the expression in b (i) lead to the definition of the ampere?
- (c) (i). Describe the construction and mode of operation of a moving coil galvanometer
- (ii). Give two constructional differences between a moving coil galvanometer used to measure current and the

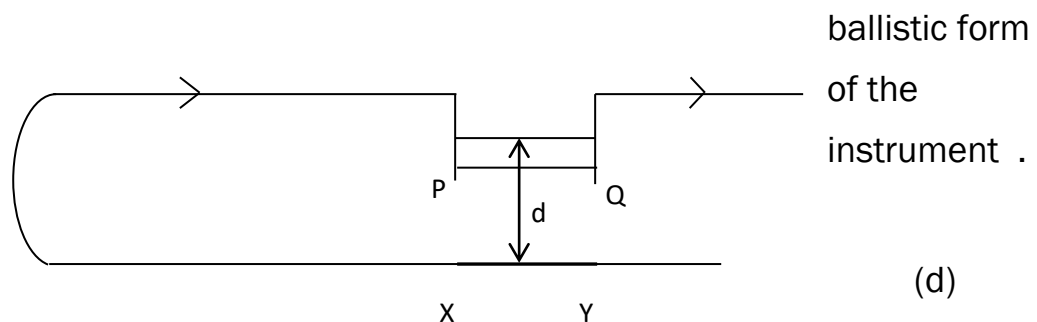

The figure shows a horizontal straight wire XY which rests on a horizontal non conducting table and another wire PQ of length 12.0cm is free to move vertically above XY. The mass per unit length of PQ is  $3\text{mgcm}^{-1}$ . A current of 3.6A through the wire was enough to maintain the wire PQ at a distance dcm from XY. Calculate:

- (i). The distance of separation, d.
- (ii). Magnetic flux density due to PQ on XY.

14. (a) (i). State the laws of electromagnetic induction.  
(ii). Describe an experiment to verify Lenz's law
- (b) (i). What are eddy currents?  
(ii). Briefly explain one practical application of eddy currents
- (c) (i). Derive an expression relating charge Q, induced in a circuit of resistance,  $R_1$  and Flux linkage  $\phi$   
(ii). A ballistic galvanometer is connected to a flat coil having 40turns of mean area  $3.0\text{cm}^2$  to form a circuit of total resistance  $80\Omega$ . The coil is held between the poles of an electromagnet with its plane perpendicular to the field and is suddenly withdrawn from the field producing a throw of 30 scale divisions. Find the magnetic induction of the field at the place where the coil was held; assuming the sensitivity of the galvanometer under the conditions is 0.4 divisions per micro coulomb.

15. (a) Define the following terms:
- (i) Angle of declination.
  - (ii) Magnetic meridian.

- (b) Describe an experiment to determine the horizontal component of the Earth's magnetic field using a tangent galvanometer.
- (c) (i) Define the term *ampere* and use this definition to show that the permeability of free space  $\mu_0 = 4\pi \times 10^{-7} \text{ H m}^{-1}$
- (ii) The diagram in figure 3 shows three straight parallel wires P, Q and R of the same length L, carrying currents of 2A, 1A and 8A respectively. The distance between P and Q is x, while that between Q and R is d. The separation between wires P and R is 0.100 m.

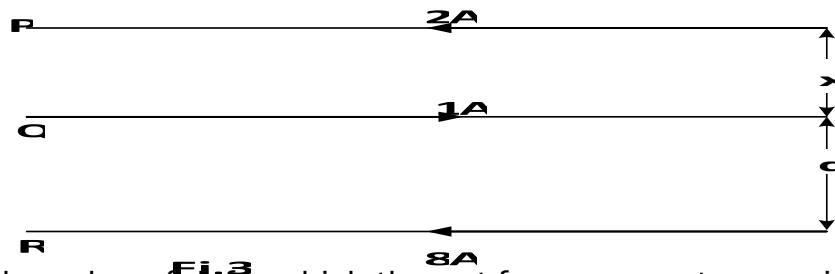

Find the value of  $d$ , for which the net force per metre on wire Q is zero.

- (d) Explain with the aid of a labelled diagram how a moving coil loud speaker works.
16. (a) What is meant by the terms:
- (i) Self-induction?      (ii) Mutual induction?
- (b) Figure 4 shows a strong bar magnet with ends S and N is attached to the free end of frictionless suspended helical spring from a fixed support. The magnet is displaced vertically downwards and left to perform vertical oscillations.

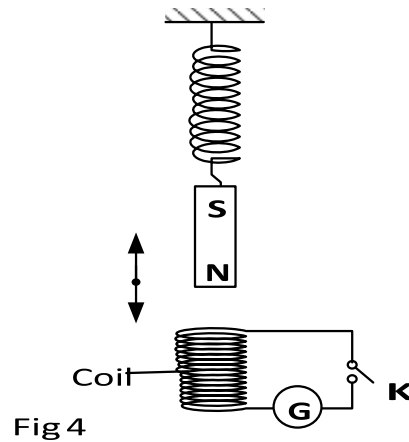

Explain the observations made when switch K is;

- (i) open.
  - (ii) closed.
- (c) A coil of 300 turns and with an area of  $0.05 \text{ m}^2$  is rotated 20 times per second in a magnetic field of flux density  $0.2 \text{ T}$ . Calculate the;
- (i) maximum e.m.f. produced across the ends of a coil.
  - (ii) torque required to maintain the rate of rotation if the current in the coil is  $0.8 \text{ A}$  when the e.m.f. generated is a maximum.
- (d) (i) Define the term *self-inductance* of a coil.
- (ii) The current in the coil rises from zero to  $4.0 \text{ A}$  in  $1.5 \text{ s}$ . If the inductance in the coil is  $0.20 \text{ H}$ . Calculate the magnitude of the e.m.f. induced in the coil.
- (e) An air-cored inductor is connected in series with a switch and a d.c source. The switch is closed and left for some time. Explain why a spark is observed across the switch contacts when the switch is re-opened.

17. a) Define the following terms;

- i) Magnetic flux.
  - ii) Magnetic flux density.
  - iii) Tesla
- b) i) With the aid of a labelled diagram, describe the mode of operation of a moving coil galvanometer.
- ii) A square coil of sides 5cm x 5cm and of 200 turns is suspended in a uniform magnetic field of flux density 0.03T with the plane of the coil parallel to the field. If a current of 25mA is passed through the coil, it causes deflection of  $60^\circ$ . Calculate the constant of the suspension.
- c) i) Write down the expression for the force on a charge,  $Q$  coulombs moving with a velocity,  $V$  at an angle of the flux density,  $B$ .
- ii) Use the expression in (c) (i) above to deduce the force on a conductor carrying a current in a magnetic field.
- iii) Two thin long parallel conductors A and B carry currents of 4.0A and 2.5A respectively separated by a distance of 5cm in vacuum, calculate the force exerted by wire B of 2 meters of wire A.
18. a) Distinguish between self-induction and mutual induction.
- b) Describe an experiment to demonstrate mutual induction.
- c) Explain the factors which affect the efficiency of a transformer.
- d) An a.c transformer operates on a 240V mains. The voltage across the secondary is 40V and has 480 turns.
- i) Find the number of turns in the primary.

- ii) If the efficiency is 85%. Calculate the current in the primary coil when a resistor of 50 ohms is connected across the secondary.
- e) An iron – coil of many turns is connected in series with an ammeter, an accumulator and a switch. The switch is closed and the movement of the pointer of the ammeter observed. The coil is then replaced by a resistor of the same resistance as the coil and the movement of the pointer observed again when the switch is closed. Explain the movement of the pointer in each case.

19. (a) Define the following as applied to earth's magnetism

- (i) angle of dip
- (ii) magnetic meridian

(b) Define the term ampere

(c) Two thin straight and parallel wires P and Q each of length 0.5m carrying currents of 2A and 3A respectively in opposite direction are joined by cotton thread of length 4cm as shown in the figure below.

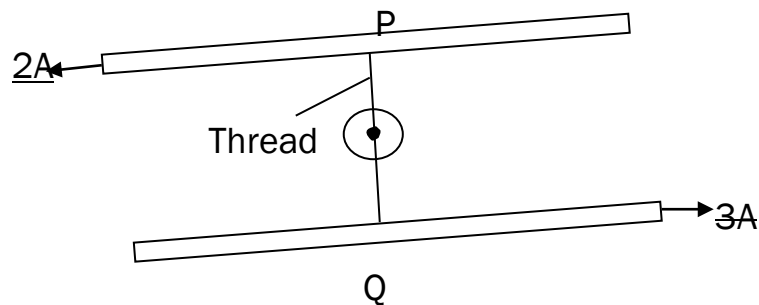

Find the

- (i) tension in the thread
  - (ii) magnetic flux density mid-way between the wires.
- (d) Describe with the aid of a diagram an accurate method for absolute measurement of current.
- (e) A large plane circular coil of mean radius 5cm and having 20 turns connected to a d.c source has a small compass needle suspended at its centre along its vertical diameter and lying along the horizontal diameter of the coil. When a current of 2A is passed through the coil deflects through  $41^\circ$ . When the current in the coil is reversed it deflects through  $39^\circ$ . Find the horizontal component of the earth's magnetic field.

20. (a) (i) State the laws of electromagnetic induction.

(ii) With the aid of a labeled diagram, describe an experiment to verify Faraday's law of electromagnetic induction.

- (b) Use the concept of conservation of energy and lenz's law to derive an expression for the e.m.f generated across the ends of a metal rod of length,  $l$ , placed across a magnetic field of flux density  $B$  and moved perpendicularly across the field with a velocity,  $V$ .
- (c) An air craft moving horizontally over the earth's surface from East to West at a velocity of  $900\text{kmh}^{-1}$  generates an e.m.f of 50mV across the tips of its wings. If the magnetic flux density at

that location is  $2.0 \times 10^{-5} \text{T}$  and the angle of dip is  $60^\circ$ , determine the length of the wing span of the air craft.

(d)

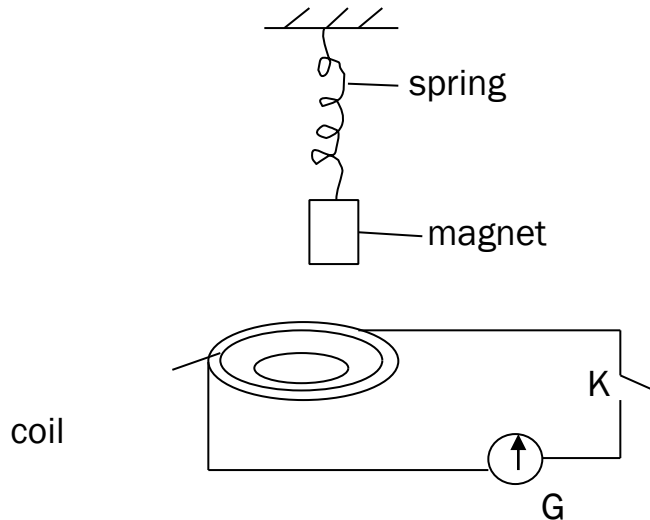

The diagram above shows a bar magnet attached to a spring whose other end is on a fixed support. Below the magnet is a circuit containing a coil, a centre zero galvanometer G and a switch, K. The magnet is vertically pulled slightly and then released to oscillate. The switch is later closed. State and explain what is observed when the switch is,

- (i) open
- (ii) closed

21. (a) Define the following terms

- (i) Magnetic flux
- (ii) Magnetic flux density
- (iii) A tesla

(b) Write down an expression for the magnetic flux density at

(i) a perpendicular distance, X from a long straight wire carrying a current,  $I$  in a vacuum.

(ii) The centre of a circular coil of N turns each of radius, R and carrying a current  $I$ ,

- (iii) The centre of an air-cored solenoid of  $n$  turns per metre each carrying current,  $I$ .
- (c) Draw a labeled diagram of a moving coil galvanometer and explains how it works.
- (d) A small circular coil of 5 turns and radius 5cm is situated at the centre of a long, solenoid of 1500 turns per metre with its axis at right angles to the axis of the solenoid. If the current in the solenoid is 2.0A, calculate the initial torque on the circular coil when a current of 0.5A flows through it
- (e) Explain why a current - carrying – conductor placed in a magnetic field experiences a force.

22. a) What is meant by
- (i) Mutual induction?
  - (ii) Self-induction?

- (b) Describe an experiment to demonstrate mutual induction.

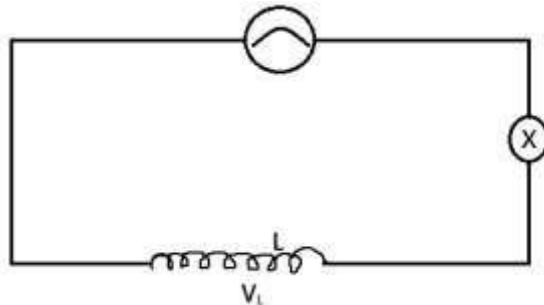

The figure above shows a circuit consisting of an air - cored coil,  $L$ , a bulb  $X$ , find an alternating voltage source,  $V_i$ , connected in series. An iron core is introduced into the coil. Explain why the

- (i) Bulb becomes dimmer
  - (ii) The iron core becomes warm
- (c)
- (i) Describe briefly the action of a transformer
  - (ii) Describe briefly four causes of inefficiency in a transformer and suggest the ways

of minimizing them

- (d) A transformer is designed to work on a 240V, 60W supply. It has 1500 turns in the primary and 100 turns in the secondary. If the current in the secondary is 3A. Calculate the efficiency of the transformer.
23. (a) Define the terms Magnetic flux and Magnetic flux density.
- (b) (i) Derive an expression for the force per unit length between two long parallel conductors carrying current.
- (ii) Use the expression above to define the SI unit of current.
- (c) An air craft is flying horizontally at  $1000\text{kmh}^{-1}$  at a point where the earth's magnetic flux density is  $2.4 \times 10^{-5}\text{T}$  and the angle of dip is  $80^\circ$ . If the distance between the wing tips is  $60\text{m}$ , calculate the potential difference induced between its wing tips.
- (d) Describe with the aid of a diagram an absolute method of determining resistance.
- (e) (i) What is meant by magnetic moment of a current carrying coil?
- (ii) A circular coil of 10 turns each of radius  $8\text{cm}$  is suspended with its plane along a uniform magnetic field of flux density  $0.2\text{T}$ . Find the initial torque on the coil when a current of  $2.0\text{A}$  is passed through it.
24. (a) State the laws of electromagnetic induction.
- (b) (i) With the aid of a labelled diagram describe the structure and action of a *d. c* generator.
- (ii) Explain the structural modifications needed to convert an *a. c* generator into a *d. c* generator.
- (c) A small rectangular coil of 12 turns and dimensions  $5\text{cm}$  by  $3\text{cm}$  is suspended inside a long solenoid of 1200 turns per metre so that its plane lies along the axis of the solenoid. The coil is connected in series with the solenoid. The coil deflects through

$40^\circ$  when a current of  $3.0A$  is passed through the solenoid. Find the torsion constant of the suspension

- (d) (i) Explain the main precautions taken in the construction of an *a. c* transformer.
- (ii) A transformer is designed to work on a  $240V$ ,  $60W$  supply. It has 3000 turns in the primary and 200 turns in the secondary and its efficiency is 80%. Calculate the current in the secondary coil.

## **B. ALTERNATING CURRENT**

1. (a) (i) Define the term *root mean square(rms) value* of alternating current.
- (ii) An alternating current  $I = I_0 \sin \omega t$  is passed through a resistance  $R$  ohms. Show that  $I_0 = (1.4142) I_{rms}$ .
- (b) (i) Distinguish between reactance and resonance of a reactive circuit. (ii) A coil of an electric kettle has a self-inductance of  $4.0H$  and a resistance of  $80\Omega$  is connected across an alternating voltage  $V = 339.41 \sin 100\pi t$  volts. Determine the steady current flowing through the kettle and its average power rating.
- (c) Describe the structure and mode of operation of a hot wire ammeter.
- (d) Figure 2 shows an iron cored coil  $L$ , connected to an a.c source and a switch  $K$ .

L

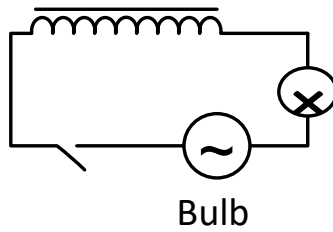

B

K a. c source

Fig. 2

Explain what takes place in the circuit when switch K is closed.

2. a) (i) What is meant by the root mean square value of an alternating current.
- (ii) Describe with the aid of a labeled diagram the structure and mode of operation of repulsion type moving ion meter.
  
- b) A sinusoidal alternating current  $I = I_0 \sin 2\pi ft$  where  $I_0$  is its amplitude and  $f$  is the frequency, connected across a coil of induction  $L$ .
  - (i) Describe the expression for the voltage across the coil.
  
  - (ii) Derive an expression for inductive reactance.
  
  - (iii) Show on the same axes how voltage and current vary with time,  $t$
  
- c) An a.c transformer operates on 240V mains. It has 1200 turns in the primary and 20 turns in secondary
  - (i) Find the voltage across the secondary
  
  - (ii) If the efficiency of the transformer is 80%. Calculate the current in the primary coil when a resistor of  $40\Omega$  is connected across the secondary.

3. (a) Define (i) Inductive reactance

(ii) Impedance

(b) An inductor of inductance  $L$  is connected across an a.c voltage source of  $V = V_0 \sin 2\pi ft$ . Derive the expression for the reactance.

(c)

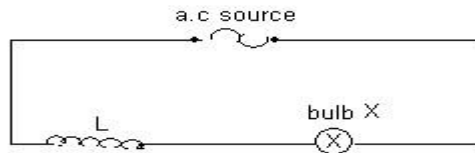

Figure 3

Figure 3 shows a circuit consisting of an air-cored coil  $L$  and bulb, and an alternating voltage source connected in series. An iron core is introduced into the coil. Explain why

(i) the bulb becomes dimmer.

(ii) the iron core becomes warm.

(d) A capacitor of capacitance  $30\mu\text{F}$  is connected in series with a resistor of  $80\Omega$ , and an a.c voltage source of  $150\text{V}$  mains and frequency  $50\text{Hz}$ . Find the:

(i) current supplied by the source

(ii) phase angle by which current leads the supply voltage.

(e) Explain why a moving coil ammeter cannot be used to measure an alternating current from the mains.

4. (a) Define impedance of a circuit and state its unit.

(b) (i) When an a.c. voltage source is connected across a capacitor of capacitance,  $C$ , a

current of  $I = I_0 \sin 2\pi ft$  flows in the circuit. Derive the expression for the reactance of the capacitor.

(ii) Explain why a capacitor is considered a wattless device.

(c)

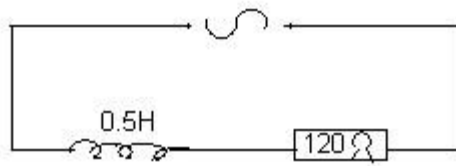

Figure 4

An inductor of inductance  $0.5\text{H}$  in series with a resistor of resistance  $120\Omega$  are connected across an a.c. voltage source of  $220\text{V}$ , and frequency  $50\text{Hz}$ . Find the:

- (i) Power dissipated in the circuit.
  - (ii) Phase angle by which voltage leads current in the circuit.
- (d) With the aid of a diagram describe how a repulsion type of moving ammeter works.

5. (a) Define root mean square value (rms) of an alternating current.

(b) A sinusoidal alternating voltage

$V = 170\sin 120\pi t$ , volts is applied across a resistor of resistance  $100\Omega$ .

Determine;-

- (i) the *r.m.s* value of the current which flows.
  - (ii) the frequency of the current through the resistor.
- (c) Describe, with the aid of a labeled diagram, how a hot wire ammeter works.
- (d) An inductor of inductance  $L$  is connected across a source of alternating voltage,
- $$v = v_0 \sin wt.$$
- (i) Find the current which flows.

(ii) Sketch, using the same axes, the variation with time of the voltage across the inductor and current through it, and explain the phase difference between them.

6. (a) (i) Distinguish between *peak value* and *root mean square value* of an alternating current.

(ii) An alternating voltage from the mains connected across an inductor of inductance 2.0 H causes a current  $I = 5.0 \sin 100\pi t$  amperes to flow through the inductor. Find the r.m.s of the applied voltage.

(b) Distinguish between *self-induction* and *mutual induction*.

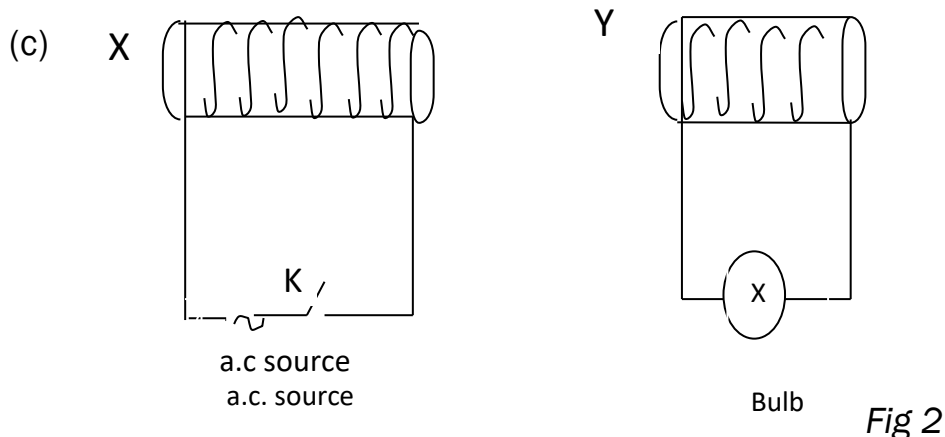

Figure 2 shows two coils, X which is soft iron cored and Y which is air cored. Explain what is observed when,

(i) Switch K is closed soft iron rod is placed in coil Y

(ii) the a.c source is replaced by d.c source and then switch k is closed.

(d) (i) With the aid of a diagram describe the structure and mode of operation of attractive type of moving iron meter

(ii) Give two advantages of the moving iron meters to moving coil meters in measuring current.

7. (a) (i). Distinguish between root mean square value and the peak value of a sinusoidal Voltage.
- (ii). Derive the relation between them.
- (b) (i). Describe with the aid of a diagram, how a thermocouple meter works.
- (c) (i). A pure capacitor of capacitance  $20\mu f$  and a  $100\Omega$  resistor are connected in series with a 240V, 50HZ supply. Calculate
- (i). The impedance of the circuit
- (ii). Power dissipated
- (d). With the aid of a labelled diagram, describe the mode of operation of an a.c generator and state what factors determine the peak value of the induced emf.
8. (a) (i) Define the terms *amplitude* and *root mean square value* of an alternating current.
- (ii) Show that the r.m.s value of alternating current of amplitude  $I_0$  is given by
- $$I_{rms} = 0.7071 I_0$$
- (b) (i) Define the term *inductive reactance*.
- (ii) Derive an expression for the inductive reactance of a pure inductor of self inductance L, connected to an alternating current,  $I = I_0 \sin 2\pi ft$ .
- (c) A sinusoidal voltage of r.m.s value 10V is applied across a 50  $\mu F$  capacitor.
- (i) Find the maximum value of charge on the capacitor.
- (ii) Draw a sketch graph of charge Q on the capacitor against time and explain the features of the graph.

(d) (i) Define the term *rectification*.

(ii) Describe how full-wave rectification can be achieved using only two rectifiers.

9. a) (i) Define the terms root mean square value of an alternating current and peak value.

(ii) Derive the relation between the terms in (a) (i) above for a sinusoidal current.

b) A source of sinusoidal voltage,  $V$  and frequency  $f$  is connected across a capacitor of capacitance,  $C$ .

i) Without using any formula explain why a current apparently flows through the capacitor and is out of phase with the voltage.

ii) Find the amplitude of the current which flows and sketch a graph of amplitude against frequency if the resistance of the connecting wires is negligible. c) i)

A current  $I = 16\sin 200\pi t$  is passed in a heater immersed in 25kg of water.

The resistance of coil of the heater is 40 ohms. Find the rise in temperature obtained in 5 minutes.

ii) State the assumption made.

10. (a) (i) Distinguish between peak value and root mean square value of an alternating voltage.

(ii) An alternating voltage from the mains connected across an inductor of

inductance 2.0H causes a current  $I = 5.0 \sin 100\pi t$

amperes to flow through the inductor. Find the R. M. S value of the

applied voltage.

(b) (i) Define the term

capacitive reactance and state its units.

(ii) A pure capacitor of capacitance,  $C$ , farads is connected across an a.c voltage

source  $V = V_0 \sin 2\pi ft$  volts. Derive the expression for its reactance.

(c) (i) Sketch a phasor diagram for the capacitor in b(ii) above.

(ii) Sketch graphs of voltage and current against time for the capacitor in b(ii) above using the same axes.

(d) (i) Derive an expression for the power absorbed in a pure capacitor connected

across an a.c source  $V = V_0 \sin 2\pi ft$  volts.

(ii) Briefly explain why a.c appears to flow through a capacitor and yet d.c does not.

11. (a) (i) Define the terms root mean square value of an alternating current and peak value.

(ii) Derive the relation between the root mean square value and peak value of an alternating current.

(b) Calculate the root mean square value of an alternating current which dissipates energy in a heating coil immersed in a liquid in a calorimeter at four times the rate at which a direct current of 5A would if passed through the same coil under the same conditions.

(c) A sinusoidal alternating current  $I = I_0 \sin \omega t$  passes through a pure inductor of inductance  $L_0$

(i) Derive an expression for the reactance of the inductor.

(ii) Using the same axes sketch graphs to show the variations of the current and voltage across the inductor.

(d) Describe with a labelled diagram the structure and action of a moving iron a

12. (a) (i) Define capacitive reactance.

(ii) An alternating voltage  $V = V_0 \sin 2\pi ft$  volts is connected across a capacitor of capacitance,  $C$ , farads. Derive an expression for the current flowing through the circuit. Hence deduce the expression for the capacitive reactance. (b)

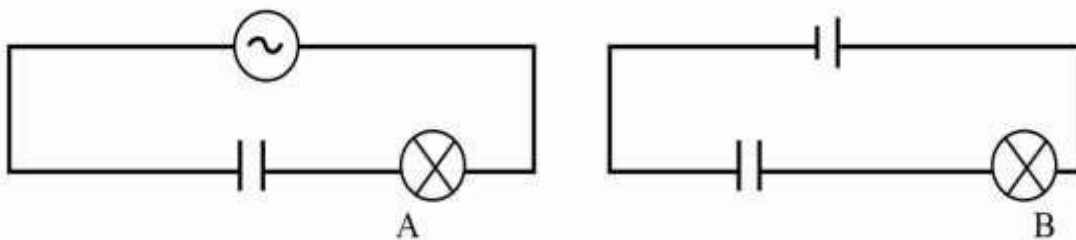

In the figure above, the bulbs **A** and **B** have the same ratings. **A** is connected in series with a capacitor across an a.c source while **B** is connected in series with an identical capacitor across a d.c source of *emf* equal to the root mean square voltage of the a.c as shown. Explain why bulb **A** lights continuously while **B** does not.

- (c) (i) What is rectification?  
(ii) With the aid of a diagram describe the action of a half wave rectifier type of meter.
- (d) Explain why on average, the power delivered to an inductor in one cycle is zero.
- (e) A sinusoidal alternating voltage of  $8.0V_{rms}$  and frequency  $1.2kHz$  is applied to a coil of inductance  $0.8H$ . Assuming that the coil has negligible resistance, calculate the root mean square value of the current.

SECTION D ONLY

## A. ELECTROSTATICS AND CAPACITORS

1. (a) (i) Define term *electric potential* at a point.  
  
(ii) If the average electric charge carried in a lightning flash is 5C and the p.d between the cloud and the ground is 800 mega volts. Determine the amount of energy transferred in the flash.
- (b) (i) What is corona discharge?  
(ii) Describe one industrial application of corona discharge.
- (c) (i) State three characteristics of equipotential surfaces.  
(ii) Explain why electric field lines are always normal to the surface of a charged conductor.
- (d) The figure 3 shows three point charges of  $-6\mu\text{C}$ ,  $+9\mu\text{C}$  and  $-2\mu\text{C}$  in space at points A, B and C respectively on the perimeter of a circle of radius 3.0cm. A fourth point charge of  $+4.0\mu\text{C}$  is placed at the centre, O of the circle.

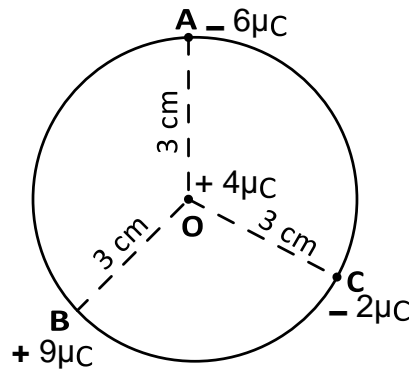

Fig. 3

Determine the net electric potential energy at point O.

2. (a) Define the terms;
  - (i) a capacitor
  - (ii) dielectric constant.
- (b) Describe an experiment to measure the dielectric constant of a parallel plate capacitor using a calibrated ballistic galvanometer.

- (c) Derive an expression for the energy stored in a capacitor of capacitance  $C$  when connected across a d.c source of e.m.f.  $V$
- (d) The figure 4 shows three identical circular parallel plate capacitors each of area  $A$  and separated by a distance  $d$ . Capacitor  $C_1$  has the space between its plates filled with a material of dielectric constant  $\epsilon_r$  and the system is connected to a 12V d.c supply.

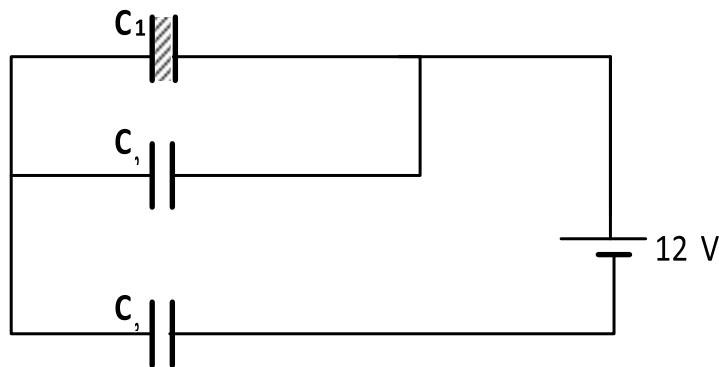

Fig. 4

- (i) Show that the effective capacitance of the capacitor network is

$$C = \frac{\epsilon_0 A (1 + \epsilon_r)}{(2 + \epsilon_r) d}$$

- (ii) Calculate the energy stored in the system, given that, the radius of each plate is 7 cm, separation between the plates of each capacitor is 2 cm and the dielectric constant inside  $C_1$  is 1.5 (Where necessary use  $\pi = \frac{22}{7}$ )

3. a) i) Define relative permittivity and capacitance of a capacitor  
 ii) Consider two parallel plates of a capacitor each having a charge numerically equal to  $Q$ . if the separation of plates is equal to  $d$  and each of the plate of area  $A$ . show

that the capacitance of this capacitor is given by  $C = \frac{\epsilon_0 A}{d}$

- (b) One of the plates of a parallel plate capacitor is suspended at one of the end of light uniform rod and pivoted at its midpoint

and carrying a mass  $M$  at the other end as shown. The plates have an area of  $A$  each and separation  $d$ . show that potential difference,  $V$ , across the plates required to balance the rod horizontally is given by

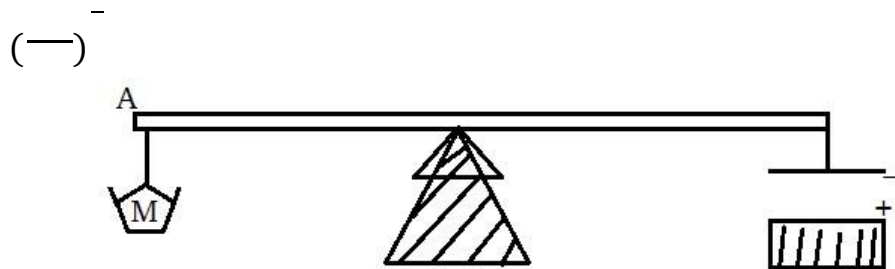

- (c) An electron is liberated from the lower plate of two parallel metal plates separated by a distance of 4cm. the upper plate has a potential of 480V relative to the lower. How long does the electron taken to reach it.
- [ $e = 1.6 \times 10^{-19} \text{ C}$  and  $m = 9.0 \times 10^{-31} \text{ kg}$ ]
- (d) Derive the expression for effective capacitance of three capacitors connected in series.
4. a) Define the term electric field intensity and electric potential
- (b) Show that the electric flux across a spherical conductor of radius  $r$  concentric with a charge  $Q$  in a vacuum is  $\frac{Q}{\epsilon_0}$
- (c) A metal sphere of diameter 200mm carries a charge of  $9.5\mu\text{C}$ . Calculate the electric potential at the
- (i) Surface of the sphere
- (ii) Centre of the sphere
- (iii) Find the electric potential energy of a charge of  $5.0\mu\text{C}$  at a point 200mm from the centre of the sphere.
- (d) Describe an experiment to show that charge resides only on the outside surface of a hollow conductor.

5. a) (i) Define electric potential at a point  
(ii)

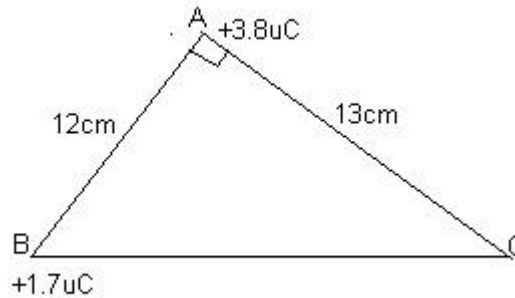

Figure4

Figure 4 above shows charges of  $3.8\mu\text{C}$  and  $1.7\mu\text{C}$  placed at the vertices A and B of the triangle. Find the work done in transferring the  $1.7\mu\text{C}$  charge from B to C.

- (b) (i) Describe how an electroscope can be used to distinguish between a conductor and an insulator.
- (ii) Explain how a charged material attracts a neutral conductor.
- (iii) Explain using appropriate mathematical illustrations why the potential of a positively charged spherical conductor increases when a positively charged material is moved closer to it.
- (c) Describe an experiment to show that charge on a charged hollow conductor resides only outside the conductor.
- (5)
- d)

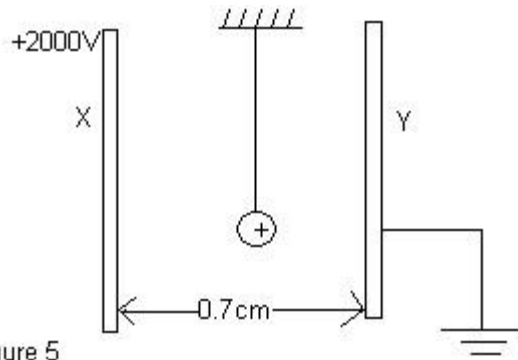

Figure 5

Figure 5 above shows two metal plates 0.7cm apart, with plate X at a potential of

+2000V relative to earth. A small particle carrying charge of  $47 \mu\text{C}$  is suspended in the space between the plates. Find the force experienced by the particle.

6. a) Define capacitance of a capacitor and relative permittivity of a material.
- (b) (i) Describe an experiment to determine to determine relative permittivity of a material using a ballistic galvanometer.
- (ii) Explain why capacitance changes when a dielectric is placed between its plates.
- (c) Two identical capacitors of capacitance  $C$  in series, across a battery of voltage  $V$ . Show that when a dielectric of relative permittivity  $\epsilon_r$  is placed in one of the capacitors, the charge stored in the network becomes  $\frac{\epsilon_r CV}{1+\epsilon_r}$  d)

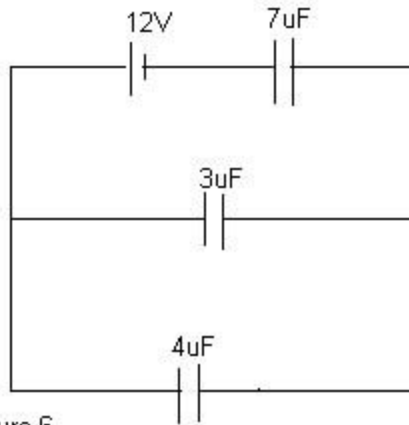

Figure 6

Three capacitors of capacitances  $3\mu\text{F}$ ,  $4\mu\text{F}$ , and  $7\mu\text{F}$  are connected in a circuit as in figure 6. Find the

- (i) Charge stored on the  $7\mu\text{F}$  capacitor.
- (ii) p.d across the  $4\mu\text{F}$  capacitor.

7. a) (i) State the coulombs law of electrostatics.  
 (ii) Define electric field intensity.

b)

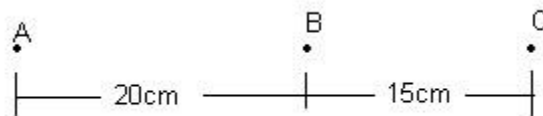

Figure 6

Figure 6 shows three points ABC in a straight line with a charge of  $+22.4\mu\text{C}$  placed at

A. Find the charge which when placed at B, makes C a neutral point.

- c) (i) What is meant by corona discharge?  
 (ii) Explain how a body may be charged and it remains at zero potential.

d) Derive the relationship between the electric field intensity,  $E$ , and the potential,  $V$ , between two points in an electric field.

e)

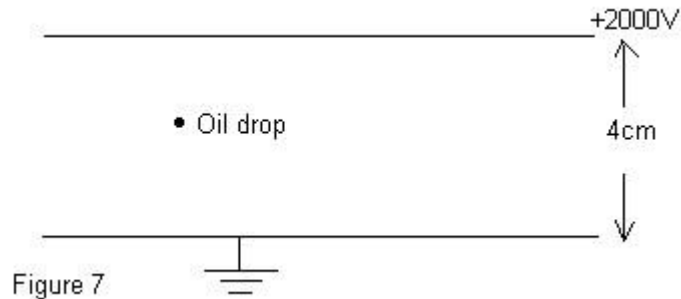

Figure 7 shows two metal plates, 4.0cm apart. The upper one is maintained at 2000V while the lower is earthed. A charged oil drop of mass  $7.3 \times 10^{-15}$  kg is introduced between the plates, and it remains stationary. Find

- (i) The number of electrons attached to it.
- (ii) The acceleration of the drop when the potential is suddenly reversed.

8. a) Define
- (i) Capacitance of a capacitor.
  - (ii) Relative permittivity.
- (b) Describe an experiment to determine the relative permittivity of a material given using a capacitor and a ballistic galvanometer.
- (c) Show that two identical capacitors connected in parallel across a voltage source store eight times the amount of energy they would store, if they were in series.

(d) Explain how the dielectric placed between the plates of a capacitor increases the capacitance.

e)

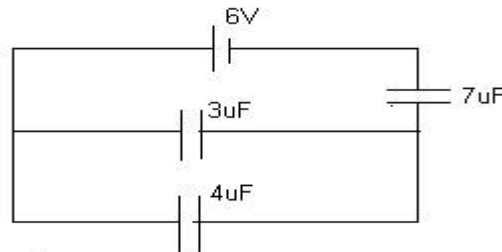

Figure 8

Figure 8 shows a network of three capacitors, of  $3\mu\text{F}$ ,  $4\mu\text{F}$  and  $7\mu\text{F}$  connected to a 6V battery. Find the

(i) Charge stored in the  $4\mu\text{F}$  capacitor.

(ii) Energy stored in the  $7\mu\text{F}$  capacitor.

9. a) State Coulomb's law of electro statics.

b) Derive the relation between electric field intensity,  $E$ , and electric potential,  $V$ , due to a charge at a point.

c) Two identical conducting balls of mass,  $m$  are suspended in air from a silk thread of length,  $l$ . When the two balls are each given

identical charge,  $q$ , they move apart as shown in Fig 5.

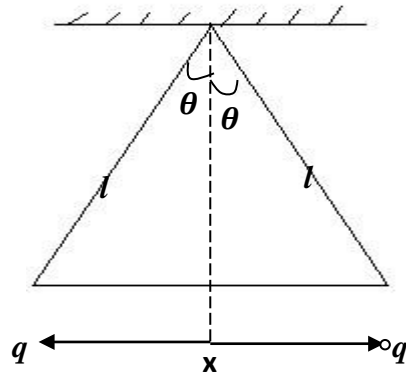

Fig.5

If at equilibrium each thread makes a small angle  $\theta$  with the vertical, show that

the separation,  $x$ , is given by  $x = \left( \frac{q^2 l}{2\pi\epsilon mg} \right)^{\frac{1}{3}}$  where  $\epsilon$  is permittivity of air.

d) Explain why a redistribution of charge occurs on uncharged metal rod when a positively charged metal sphere is brought near to one end.

e) Describe with the aid of a diagram, the mode of operation of the Vander Graff generator.

10. a) Define the following:-

(i) Capacitance.

(ii) Dielectric.

b) Describe an experiment that can be used to show how capacitance of a capacitor depends on the permittivity of a dielectric.

c) Derive an expression for the energy stored in a capacitor of capacitance  $C$  charged to a p.d  $V$ .

d)

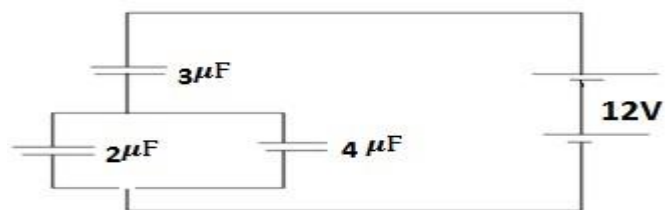

Fig.6

A battery of e.m.f 12V is connected across a system of capacitors as shown in fig 6. Find the;-

(i) Charge on the 3 μF capacitor.

(ii) Energy stored in the 4 μF capacitor.

e) Describe how the unknown capacitance of a capacitor can be determined using a ballistic galvanometer.

11. a) State Coulomb's law of electrostatics.

b)

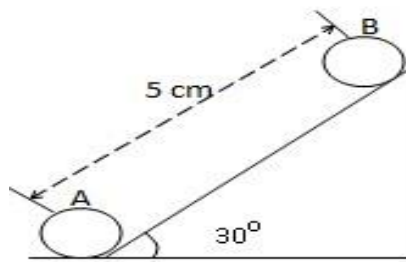

Fig 4

Figure 4 shows a charged metal sphere B of mass 100mg held stationary on a smooth inclined plane by an identically charged metal sphere A placed at the bottom of the incline.

(i) Find the magnitude of charge on the metal spheres.

(ii) If the angle of the incline plane is doubled by what distance will sphere B shift for it to remain stationary.

c) With the aid of a diagram describe the mode of operation of a Van de Graaff generator.

d) (i) Distinguish between electric field intensity and electric potential.

(ii) Describe an experiment to show that when two objects are rubbed together they acquire equal but opposite charge.

12. a) Define the terms dielectric constant and dielectric strength.

(b) (i) Describe an experiment to show how capacitance of a capacitor varies with the permittivity of the dielectric material.

- (ii) An air-parallel plate capacitor whose plates have area  $4\text{cm}^2$  and are  $2\text{cm}$  apart is charged to a potential difference of  $80\text{V}$ . The capacitor is then isolated and a dielectric material of dielectric constant  $2.5$  is inserted between the plates and covered half the area of the plates. Find the charge in the energy stored by the capacitor.
- (c) Derive the expression for the energy stored by the capacitor of capacitance  $C$  charged to a potential difference  $V$ .      d)

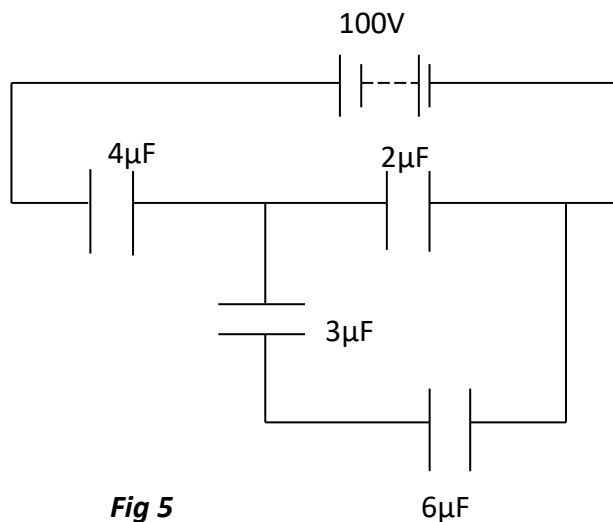
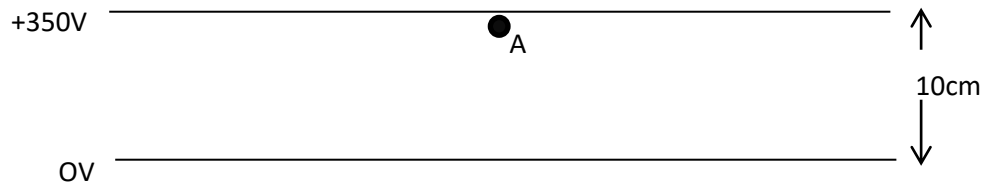

**Fig 5**

Figure 5 shows a network of capacitors connected to a battery of e.m.f  $100\text{V}$ . Find

- (i) the effective capacitance.
- (ii) the energy stored by the  $4\mu\text{F}$  capacitor.
13. a) (i). Explain the meaning of the terms capacitance and dielectric constant.
- (ii). State three desirable properties of a dielectric material for the use in a high quality capacitor

- (b) Derive an expression for the electrical energy stored in the capacitor of capacitance  $C$  when charged to a potential difference  $V$
- (c) Describe an experiment to determine the relative permittivity,  $\epsilon_r$ , of the dielectric material using the ballistic galvanometer
- (d) A parallel plate capacitor consists of two plates of area  $1.00 \times 10^{-2} \text{m}^2$  placed a distance  $2.00 \times 10^{-2} \text{m}$  apart in air. The capacitor is charged so that the potential difference between the plates is  $1000 \text{V}$ . Calculate
- (i). the electric field intensity between the plates (neglect the edge effect)
- (ii). the capacitance of the capacitor
- (iii). the energy stored in the capacitor
14. a) (i). State coulomb's law of electrostatics
- (ii). Derive the expression for electric potential energy of two point charges,  $Q_1$  and  $Q_2$  a distance  $r$  apart
- (b) Describe an experiment to show that a charge resides outside a hollow conductor
- (c) (i). Define electric field intensity
- (ii). Describe how a conducting body may be positively charged but remains at zero potential
- (d) The diagram shows two horizontal parallel conducting plates in vacuum



A small particle of mass  $4 \times 10^{-12}$  kg carrying a positive charge of  $3.0 \times 10^{-14}$  C is released at A close to the upper plate.

- (i). What total force acts on this particle?
- (ii). Calculate the kinetic energy of the particle when it reaches the lower plate

## B. ELECTRICITY

1. a) Define the following terms:
  - (i) Internal resistance,
  - (ii) Electromotive force of a battery.
- b) You are provided with the following items; a battery, a switch, a resistance box, an ammeter and a voltmeter. Describe a suitable graphical method that you would employ in order to determine the e.m.f. and internal resistance of the battery.
- c)
  - (i) Define the term temperature coefficient of resistance of a material and state its S.I unit.
  - (ii) The graph in the figure 5 shows the variation of resistance of a conductor W with temperature.

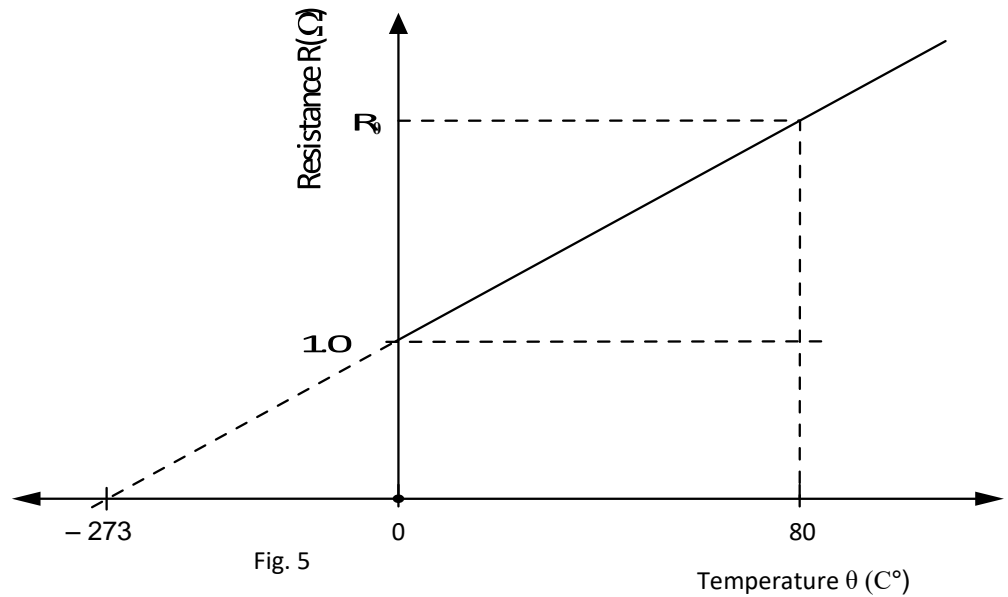

Use the graph to determine, the temperature coefficient of resistance of the material  $\alpha$  and the value of  $R_{\theta}$  when the temperature is  $80^{\circ}\text{C}$ .

- d) (i) State two important uses of high resistivity wires such as those made of Nichrome.
- (ii) Explain why the temperature of a wire increases when a current is passed through it.

2. a) (i) Define the term electromotive force and volt.
- (ii) Explain why the temperature of electrical conductor rises when the current passes through it.
- b) If a device of e.m.f  $E$  and internal resistance,  $r$ , passes a steady current  $I$ , through a load of resistance,  $R$  show that the maximum power delivered to the load occurs when  $R = r$
- c) Consider a portion of copper wire of length  $L$  and area of cross section,  $A$ , through which current,  $I$ , flows for a time  $t$ , Show that the drift speed of the electron is given

by 
$$V = \frac{I}{nAe}$$

- d) A millimeter with a full scale deflection of 5.0mA and a coil resistance of  $50\Omega$  is to be used as a voltmeter with a full scale deflection of 2.0V. What size resistance needs to be placed in series with the meter
3. a) (i) Define one volt
- (ii) Two identical cells of emf 1.5V and internal resistance  $1\Omega$  each are connected in parallel, and then in series with two resistors of  $2\Omega$  and  $3\Omega$ . Find the power dissipated in the  $3\Omega$  resistor.
- b) (i) Define electrical resistivity of a material
- (ii) Describe an experiment to determine the electrical resistivity of a material in form of a wire, using a meter bridge.
- (iii) The electrical resistivity of mild steel is  $15 \times 10^{-8} \Omega\text{m}$  at  $20^\circ\text{C}$  and its temperature coefficient is  $50 \times 10^{-6} \text{K}^{-1}$ . Calculate the resistivity at  $80^\circ\text{C}$ .
- c) Explain why the resistance of metals increases with increase in temperature while that of semi-conductors reduce.
4. a) Define one coulomb, and one volt.
- b) (i) Derive the expression for the electrical energy dissipated in a resistor of resistance,  $R$  ohms carrying current,  $I$ , amperes, for  $t$ , seconds.
- (ii) A network of resistors of  $3\Omega$ ,  $4\Omega$ ,  $5\Omega$  and  $6\Omega$  are connected with batteries of 15V and 12V as Figure 5 below.

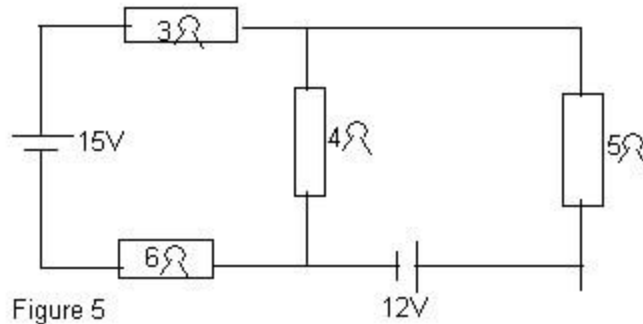

Figure 5

Find the

- (i) Current passing through the  $5\Omega$  resistor.
  - (ii) Power dissipated in the  $3\Omega$  resistor.
- c) Describe an experiment to determine the dependence of resistance on the area of cross-section of a conductor.
- d) A coil of wire has resistance of  $51.2\Omega$  at  $30^\circ\text{C}$  and  $52.4\Omega$  at  $80^\circ\text{C}$ . Calculate the temperature co-efficiency of resistance of the coil.

5. a) (i) Define a volt.

(ii) Derive the formula of the three resistors in parallel.

(iii) A network of resistors of  $2\Omega$ ,  $6\Omega$ ,  $1.5\Omega$  and  $3\Omega$  are connected to a  $12\text{V}$  d.c supply of negligible internal resistance as shown in figure 3.

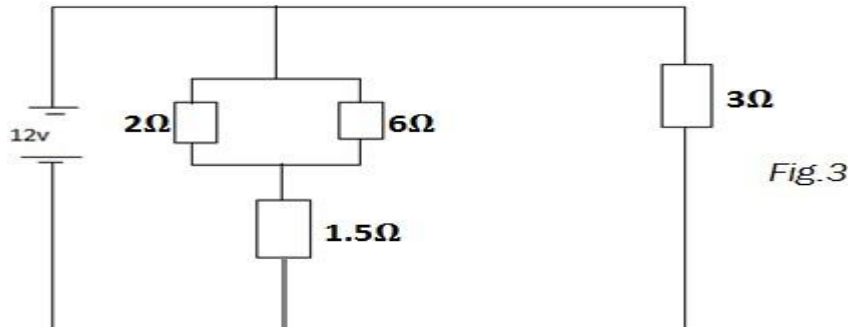

Fig.3

Calculate the power dissipated in the  $6\Omega$  resistor.

- b) Describe how you would use a slide potentiometer to measure the internal resistance of a dry cell.
- c) In figure 4, AB is a uniform resistance wire of length 1.00m and internal resistance  $10.06\Omega$ . E is an accumulator of *e.m.f* 2.0V and internal resistance  $1.0\Omega$ .

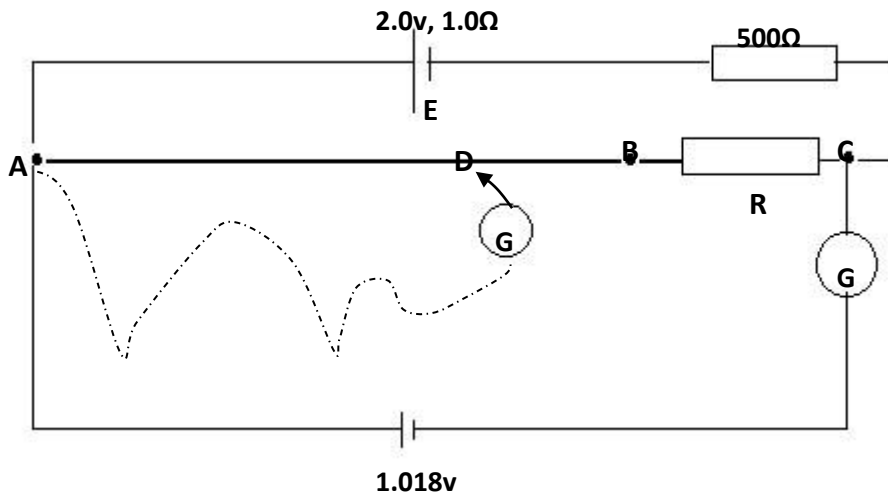

Fig.4

When a standard cell of *e.m.f* 1.018V is connected in series with a galvanometer G across AC, the galvanometer shows no deflection. When the standard cell is removed and a thermocouple connected via the galvanometer, G, as shown by the dotted line, G shows no deflection when  $AD = 41.0\text{cm}$ . Calculate:-

- (i) Value of R.
- (ii) *e.m.f* of the thermo couple.

6. a) Define the terms resistivity and temperature coefficient of resistance of a conductor.
- b) (i) Describe an experiment to determine resistivity of a wire.  
(ii) Two wires A and B of resistivities  $\rho_1$  and  $\rho_2$  respectively have the same length and cross section area. The wires are connected in series and a cell of e.m.f,  $\varepsilon$  is connected across the wires. Show that the P.d across wire A is given by

$$V_1 = \frac{\rho_1 \varepsilon}{\rho_1 + \rho_2}$$

- c) In an experiment carried out at 0°C. The following information was obtained about wires of nichrome and silver

	Nichrome	Silver
Length (m)	1.20	–
Diameter(mm)	1.20	0.80
Resistivity ( $\Omega\text{m}$ )	$1.0 \times 10^{-6}$	$2.8 \times 10^{-7}$
Temperature coefficient ( $\text{k}^{-1}$ )	$4.0 \times 10^{-4}$	$3.0 \times 10^{-4}$

- (i) If the ratio of the resistance of nichrome to resistance of silver was 1.2, what was the length of silver?  
(ii) What would the ratio of resistance become if the temperature of the wires was raised by 100K?

d)

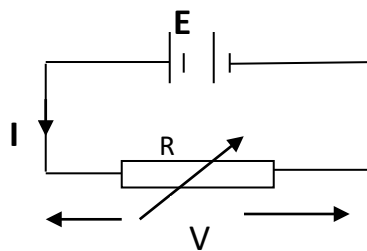

Fig 3

Figure 3 shows a battery e.m.f  $E$  connected across a variable resistor  $R$ . Sketch on the same axes a graph of  $E$  and current  $I$  against the load  $R$  and explain the features of the graph.

7. a) A battery of emf  $E$  volts and internal resistance  $5\Omega$  is connected in series with a resistor of variable resistance  $R$
- Sketch a graph to show the variation of terminal p.d  $V$  with  $R$ .
  - Derive the condition for maximum power dissipated in the variable resistance
  - what will be the value of  $R$  when the efficiency of the circuit is 80%?
- b)
- State Ohm's law
  - Describe an experiment to verify Ohm's law
- c)
- Explain what is meant by electric resistivity and show that its unit is  $\Omega\text{m}$ .
- d). In an experiment to investigate the variation of resistance with temperature, a nickel wire and a  $10\Omega$  standard resistor were connected in the gaps of the meter bridge. When the nickel wire was at  $0^\circ\text{C}$  a balance point was found 40cm from the left end of the bridge wire adjacent to the nickel wire. When it was at  $100^\circ\text{C}$  the balance point was found to occur at 50cm. Calculate
- the temperature of the nickel wire (on its resistance scale) when the balance point was at 42cm.
  - the resistivity of the nickel wire at this temperature if the wire was then 150cm long and cross-sectional area  $2.5 \times 10^{-4} \text{ cm}^2$

**NB:**

1. These are just supplementary questions please. Thus do all of them in addition to what you already have.
2. There are various questions in the book I sent via [standardhighschoolzana.com](http://standardhighschoolzana.com) website so visit it and attempt all those questions under topics
3. This is the first edition of Physics II questions. Thus for more editions contact 0789-532 159, 0703-583 009 or [muzamiru11@gmail.com](mailto:muzamiru11@gmail.com).